

TrickleMeter®

Low Flow Flowmeters

Description

The Flow Technology TrickleMeter® is ideal for measuring very low flows of low- to high-viscosity liquids. Its positive displacement design provides rugged, reliable operation for a variety of industrial applications. The SRP sensor is specially matched to the TrickleMeter® providing a reliable pulse output at the full range of flows.

Features

- Only two moving parts
- 1000 PSI
- Stainless steel case, carbide shafts
- Up to 100:1 turndown
- 3/8" NPT connections
- Non-intrusive sensor
- Easy installation and maintenance
- Wide range of applications
- Handles pulsating flow systems
- Ideal for additive injection



TrickleMeter®
Low Flow Flowmeters

Protected by one or more U.S. Patents:
4641522, 4815318, 4911010, 4996888, 5027653, 5325715

Principle of Operation

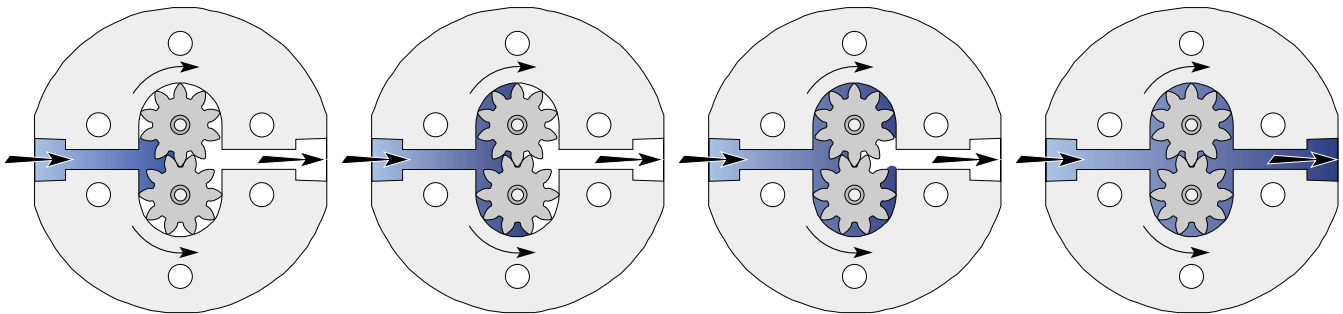

TrickleMeter® flowmeters use two rotating impellers driven by the flowing liquid. A non-intrusive sensor responds to the passing teeth on one impeller and generates a pulsed output signal. Each pulse represents a known volume of liquid that is captured between the teeth of the impellers. A K-Factor converts the pulses into engineering units for remote data collection and digital display.

Flowmeter Assembly Diagram

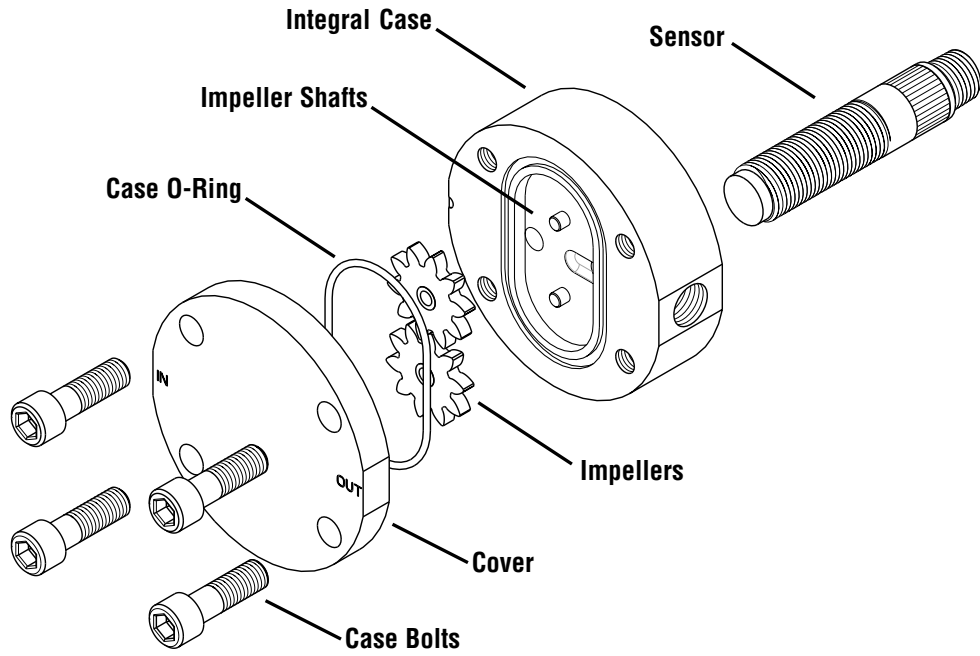

Dimensions

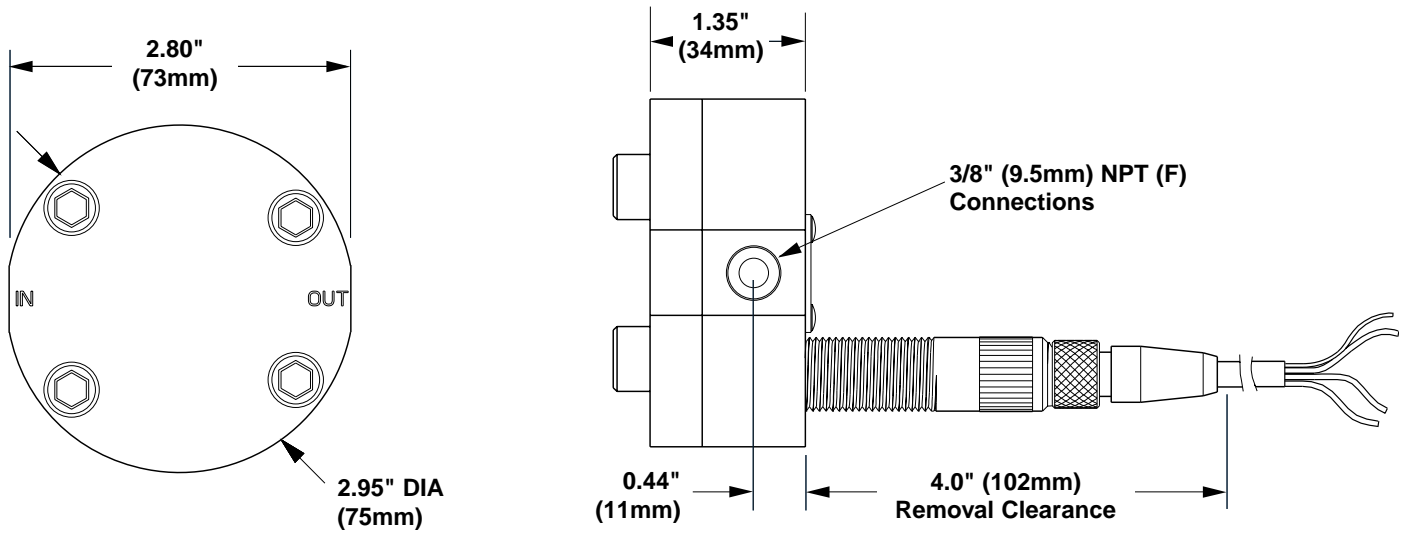

Caution: Finger-tighten sensor into meter body.
WARNING: Do not pressurize meter without sensor installed. Do not run for any period of time without media in meter. Severe damage will result.

Typical Calibration Curves

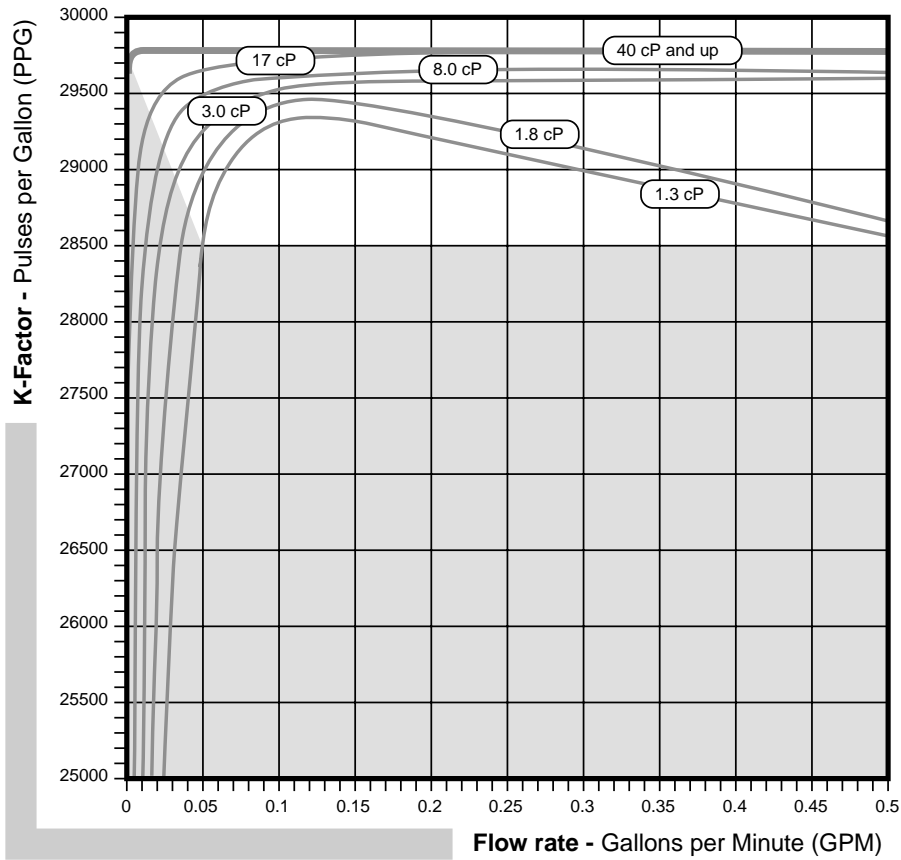

Standard flowmeter calibrated using standards traceable to the National Institute of Standards and Technology (NIST).

Pressure Drop Across Meter

$$\Delta P = e^{\left(\frac{\ln(\text{viscosity}) + b \ln(\text{flow}) + a}{c}\right)}$$

viscosity is in cP, flow is in GPM, ΔP is in PSI

with:

a = 0.0082
b = 0.9642
c = 0.9659

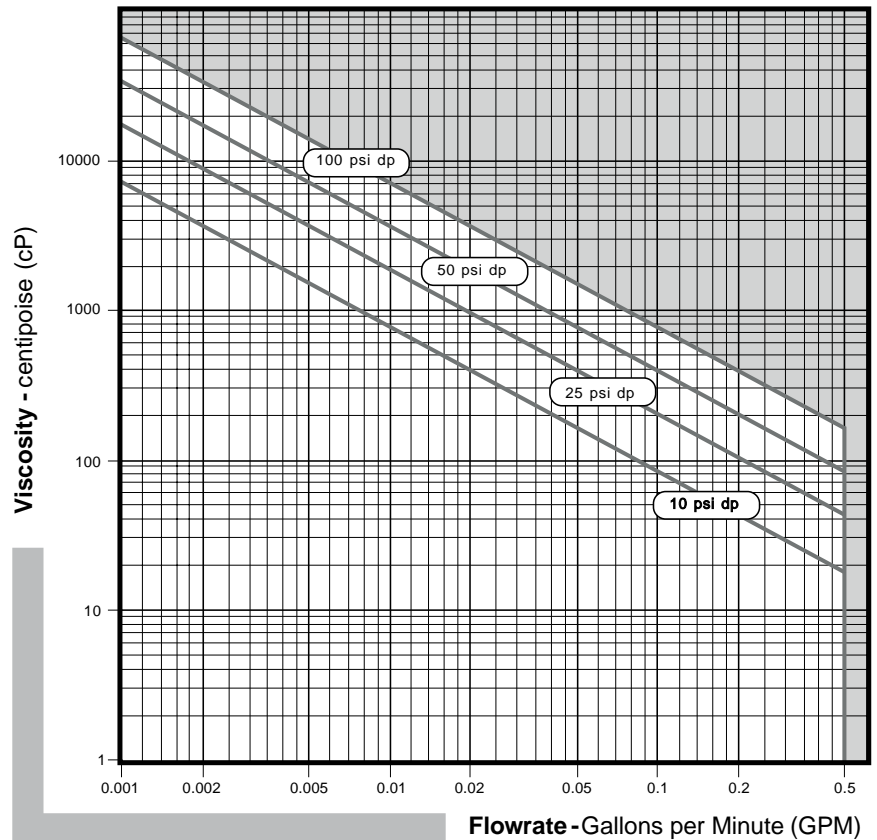

□ Recommended Operating Range
■ Not Recommended Operating Range

Specifications

Operating Temperature	-20° F to +450° F (-29° C to +232° C)
Operating Pressure	1,000 psig (6.89 MPa)
Turndown Ratio (ratios based on maximum rated flow rate)	
Low-viscosity fluids	10:1 standard (1.0 cP to 3.0 cP)
Medium-viscosity fluids	100:1 standard (>3.0 cP)
High-viscosity fluids	100:1 standard (>3.0 cP)

Repeatability (Reference Accuracy)	±0.05% of rate on medium/ high-viscosity fluids
---	--

Accuracy (Linearity)	
Medium/high-viscosity fluids	±0.5% of rate over upper 80% of full span typical
With enhanced signal conditioning	Up to ±0.1% of rate over full turndown range

Flow Rate	
Minimum	0.005 GPM (0.019 L/min)*
Maximum	0.5 GPM (1.9 L/min)*

Weight	2.5 lbs (1.1 kg)
---------------	------------------

* See turndown ratio

Output
(Refer to individual product sheets for complete specifications)

Sensors (1 required per meter)
Surface Reference Sensor: 7–30 VDC square-wave pulse
depending on supply
voltage, 3-wire

Signal Conditioners,
Transmitters
Refer to individual product
sheets available from
Flow Technology

Materials of Construction

Integral Body (Case), Cover(s)	316 stainless steel, standard
Shafts	Tungsten Carbide
Impellers	440C, Hardened
O-Rings	Viton® or Teflon® standard
Bolts	Black-Oxide Grade 8 standard

Note: High Strength Corrosion Resistant A-286 Stainless
Steel bolts are available.

Recommended Filtration

Sieve No.	625
Micron	20

Model Numbering System

L 0 0 □ - □ □ □ □ - I 2 - □ □ □ □ □ □ □

**Basic
Model No.**

Nominal Size
00 = .005–.5 GPM

Meter Type
I = Intermediate Pressure
(1,000 psi)

Case Material
6 = 316 SST with black-oxide
steel Grade 8 bolts
C = 316 SST with A-286 High
Strength Grade 8 bolts

Special Designator

000 = Standard Meter

Connection Size

03 = 3/8"

Connection Type

1 = NPT (Female)

Impeller Material

T = 440C, Hardened

O-Ring Material

1 = Viton®

9 = Teflon®

Shaft Material

C = C2 Tungsten Carbide

Specifications are for reference only and are subject to change without notice.

Local Representative:



4250 E. Broadway Road, Phoenix, Arizona 85040 USA
Tel: (602) 437-1315 • Fax: (602) 437-4459 • Toll Free: 1-800-528-4225
E-mail: ftimarket@ftimeters.com • Web: www.ftimeters.com