



# FT Series

## Turbine Flowmeters

### Description

Flow Technology's FT Series turbine flowmeters utilize a proven flow measurement technology to provide exceptionally reliable digital outputs. Because of their versatility, these flowmeters are the solution for a wide variety of liquid and gas flow sensing applications.

FT Series turbine flowmeters, which range in size from 3/8 inch to 24 inches, offer a high turn-down capability, repeatability of  $\pm 0.05\%$  (liquid) and  $\pm 0.1\%$  (gas) of reading, and excellent speed of response. The precision, axial-mounted rotor design of the standard turbine flowmeter allows it to operate effectively in flow rates from 0.03 to 50,000 GPM to (0.11 to 189,000 LPM) in liquid and 0.09 to 15,000 ACFM (2.55 to 424,800 ALPM) in gas, and pressures as high as 4,000 BAR (58,000 psi) for certain applications. Linearity is rated at  $\pm 0.5\%$  of reading over the normal 10:1 turn-down range for liquid (premium linearity of  $\pm 0.25\%$  offered) and  $\pm 1.0\%$  of full scale over the normal range for gas. All turbine flowmeters can achieve  $\pm 0.1\%$  linearity with linearizing electronics.

A choice of construction materials can be specified for the turbine flowmeter's housing, rotor, bearings and shaft, including standard stainless steel, and exotic materials for specialized applications.

### Applications

Flow Technology offers a wide range of turbine flowmeters and custom-engineered designs for liquid and gas applications to meet the demands of the Aerospace, Industrial and Automotive users. Examples of applications include fuel consumption, hydraulics, coolant, gas injection, batching, ultra-pure water and feedback of process variables in control systems.

### Operation

A volumetric device that measures the flow of both liquid and gases, the turbine flowmeter's design is based on a freely-suspended turbine rotor which is rotated by the flow of fluid (liquid or gas) through the meter body.



### FT Series

Turbine Flowmeters

### Features

- High turndown capability, up to 100:1
- Excellent speed of response
- Repeatability of  $\pm 0.05\%$  (liquid) and  $\pm 0.1\%$  (gas) of reading
- Linearity of  $\pm 0.5\%$  of reading over normal 10:1 range for liquid,  $\pm 1\%$  of full scale over the normal 10:1 range for gas
- Linearity of  $\pm 0.1\%$  with linearizing electronics
- Flow rates from 0.03 to 50,000 GPM (0.11 to 189,000 LPM) in liquid, 0.09 to 15,000 ACFM (2.55 to 424,800 ALPM) in gas
- Withstands pressures up to 400 BAR (5,800 psi), operation to 4,000 BAR (58,000 psi) optional
- Standard materials of construction are 316 SS housing and 430° F SS rotor. Additional materials available
- End fittings available are NPT, AN (MS), Hose Barb, ANSI Flanges, SAE, Tri-clamp and special configurations as required
- High Shock meter designs available

## Operation (cont'd)

An external pickoff senses the passing of each rotor blade, generating a frequency output. The frequency is directly proportional to the velocity of the fluid, and since the flow passage is fixed, the turbine's rotational speed is a true representation of the volumetric rate of fluid flowing through the flowmeter.

## Specifications

### Applicable to Both Liquid and Gas Flowmeters

#### Materials Of Construction

Standard	316 SST Housing 430F SST Rotor 440 C Ball Bearings Stainless steel all other wetted parts
----------	--

Other materials of construction optional (see model number chart).

**Operating Temp. Range** Defined by pickoff and bearing selection

**Bearing Type** Temperature Limits:  
440 C stainless steel ball bearings -450° F to 300° F (-270° C to 150° C)  
Note: Not recommended for water service.

Ceramic journal bearings -100° F to 800° F (-75° C to 425° C)

Graphite journal bearings -100° F to 550° F (-75° C to 290° C)

Tungsten carbide journal bearings -100° F to 1,200° F (-75° C to 650° C)  
Note: Journal bearings are for liquid service only.

**Pickoff Type** Temperature Limits:  
Magnetic -430° F to 350° F (-260° C to 177° C)  
*Output:* 10 mV min.

High Temp. Magnetic -430° F to 750° F (-260° C to 400° C)  
*Output:* 10 mV min.

Modulated Carrier (RF) -300° F to 350° F (-185° C to 177° C)

High Temp. (RF) Up to 750° F (400° C)

#### Pickoff Electronic Connections

MS Connector	
2-pin, standard pickoff	15-89515-101
3-pin, amplified pickoff	15-89515-102
4-pin, pickoff with RTD	15-93825-01

Threaded Connection with Leads  
Junction Box with Terminal 73-31836-105

**Operating Pressure Range** Defined by end connection rating up to 400 BAR (5,800 psi) standard. Special high pressure available up to 4,000 BAR (58,000 psi)

#### Filtration Recommendations

Ball Bearings 10 micron to 100 micron (with less filtration for large sizes)

Journal Bearings 100 micron

Either a Magnetic or Modulated Carrier (RF) pickoff with a range extending amplifier can be used to sense the rotation of the turbine rotor and provide an electrical output that is proportional to the process flow rate. A benefit of the RF pickoff is that it extends the low flow range of the meter by eliminating magnetic drag on the rotor.

The frequency output is processed by complementary electronics, ranging from basic amplifiers, indicators and totalizers, to more complex flow computers which compensate for all measurable process parameters and provide ultimate volumetric or mass flow measurement accuracy.

## Liquid Service

Liquid service performance specifications are based on a viscosity of 1.2 centistokes using ball bearings.

**Calibration Accuracy**  $\leq \pm 0.05\%$  of reading (accuracy of primary flow calibration standard directly traceable to NIST)

**Repeatability**  $\leq \pm 0.05\%$  of reading

**Linearity**  $\leq \pm 0.5\%$  of reading over the normal 10:1 flow range (premium linearity of  $\pm 0.25\%$  offered)

$\pm 0.1\%$  of reading with linearizing electronics

**Pressure Drop** Less than 700 mBAR (10 psid) at maximum 10:1 flow rate

**Dynamic Response** Less than 10 mS response to a step input change of flow rate

## Gas Service

Gas service performance specifications are based on air at standard conditions 1 BAR and 20° C (14.7 psia and 68° F) with ball bearings.

**Calibration Accuracy**  $\leq \pm 0.3\%$  of reading (accuracy of primary flow calibration standard directly traceable to NIST)

**Repeatability**  $\leq \pm 0.1\%$  of reading

**Linearity**  $\leq \pm 1.0\%$  of full scale over the normal 10:1 flow range  
 $\pm 0.1\%$  of reading with linearizing electronics

**Pressure Drop** Less than 40 mBAR (16 inches of water) at normal 10:1 maximum flow rate

**Pressure Tap** Optional on all gas meters 7/16-20UNJF-3A thread, MS33656, for flared 1/4" O.D. tube, AN806-4

# Model Numbering System

## FT Sizing

	5 DIGIT SERIES & SIZE	END FITTING NOMINAL INCHES	METER I.D.		NORMAL FLOW RANGE 10:1				EXTENDED RANGE									BASED ON NORMAL RANGE			
									BALL BEARINGS				JOURNAL BEARINGS				ALL	NOMINAL K-FACTOR APPROX.		MAX. FREQ. APPROX.	
									PICKOFFS						ALL MAX			P/L	P/G	Hz	
									RF MIN		MAG MIN		RF MIN		MAG MIN						
LPM		GPM		LPM		GPM		LPM		GPM		LPM		GPM							
LIQUID	FT 4-6	3/8	7.6	0.300	0.95	9.5	0.25	2.5	0.11	0.03	0.38	0.10	0.38	0.10	0.45	0.12	11	3	12680	48000	2000
	FT 4-8	1/2	7.6	0.300	0.95	9.5	0.25	2.5	0.11	0.03	0.38	0.10	0.38	0.10	0.45	0.12	11	3	12680	48000	2000
	FT 6-8	1/2	9.4	0.370	1.9	19	0.5	5.0	0.19	0.05	0.45	0.12	0.57	0.15	0.76	0.20	19	5	6600	25000	2100
	FT 8-8	1/2	10	0.400	2.8	28	0.75	7.5	0.30	0.08	0.6	0.16	0.76	0.20	0.95	0.25	30	8	4200	16000	2000
	FT-08	1/2	11	0.440	3.8	38	1.0	10.0	0.38	0.10	0.76	0.2	0.95	0.25	1.1	0.3	38	10	3170	12000	2000
	FT-10	*5/8, 3/4	13	0.500	4.7	47	1.25	12.5	0.57	0.15	1.1	0.3	1.1	0.3	1.5	0.4	56	15	2540	9600	2000
	FT-12	3/4	14	0.560	7.6	76	2.0	20	0.95	0.25	1.8	0.5	1.9	0.5	1.9	0.5	94	25	1580	6000	2000
	FT-16	1	22	0.860	19	190	5.0	50	2.3	0.6	3.7	1.0	3.8	1.0	3.8	1.0	227	60	635	2400	2000
	FT-20	1 1/4	25	1.00	34	340	9.0	90	3.8	1.0	5.6	1.5	3.8	1.0	5.7	1.5	378	100	345	1300	1950
	FT-24	1 1/2	34	1.32	57	570	15	150	6.0	1.6	9.4	2.5	6.0	1.6	9.5	2.5	605	160	160	600	1500
	FT-32	2	44	1.75	85	850	22	225	9.5	2.5	13	3.5	9.5	2.5	13	3.5	946	250	92	350	1300
	FT-40	2 1/2	56	2.22	151	1510	40	400	17.0	4.5	19	5.0	17	4.5	19	5.0	1700	450	48	180	1200
	FT-48	3	73	2.87	246	2460	65	650	N/A	N/A	28	7.5	N/A	N/A	28	7.5	2838	750	20	75	812
	FT-64	4	98	3.87	473	4730	125	1250	N/A	N/A	57	15	N/A	N/A	57	15	5677	1500	8	30	625
	FT-96	6	152	6.00	1135	11350	300	3000	N/A	N/A	190	50	N/A	N/A	190	50	13246	3500	7.5	28	1400
	FT128	8	203	8.00	2082	20820	550	5500	N/A	N/A	227	60	N/A	N/A	227	60	22710	6000	3.7	14	1300
	FT160	10	254	10.00	3217	32170	850	8500	N/A	N/A	378	100	N/A	N/A	378	100	37848	10000	2.2	8.5	1200
	FT192	12	305	12.00	4542	45420	1200	12000	N/A	N/A	568	150	N/A	N/A	568	150	56772	15000	1.3	5.0	1000
GAS					ALPM		ACFM	ALPM	ACFM	ALPM	ACFM					ALPM	ACFM	P/L	P/Ft <sup>3</sup>		
	FT 2-8	1/2	9.4	**0.370	2.83	28.3	0.1	1.0	2.55	0.09	N/A	N/A	N/A	N/A	N/A	N/A	35.5	1.25	3284	93000	1550
	FT 4-8	1/2	7.6	**0.300	7.0	70	0.25	2.5	5.7	0.2	N/A	N/A	N/A	N/A	N/A	N/A	85	3.0	1589	45000	2000
	FT 6-8	1/2	9.4	**0.370	14.0	140	0.5	5.0	7.1	0.25	11.4	0.4	N/A	N/A	N/A	N/A	141.6	5.0	848	24000	2000
	FT 8-8	1/2	10	**0.400	21.2	212	0.75	7.5	11.5	0.4	14.2	0.5	N/A	N/A	N/A	N/A	226.5	8.0	565	16000	2000
	FT-08	1/2	11	**0.440	28.3	283	1.0	10	14.5	0.5	21.3	0.75	N/A	N/A	N/A	N/A	283	10	424	12000	2000
	FT-10	*5/8, 3/4	13	0.500	35.4	354	1.25	12.5	17	0.6	28.4	1.0	N/A	N/A	N/A	N/A	424	15	339	9600	2000
	FT-12	3/4	14	0.560	56.6	566	2	20	28.5	1.0	42.5	1.5	N/A	N/A	N/A	N/A	708	25	212	6000	2000
	FT-16	1	22	0.860	141.6	1416	5	50	42.5	1.5	71	2.5	N/A	N/A	N/A	N/A	1699	60	85	2400	2000
	FT-20	1 1/4	25	1.00	255	2550	9	90	71	2.5	142	5	N/A	N/A	N/A	N/A	2832	100	46	1300	1950
	FT-24	1 1/2	34	1.32	425	4250	15	150	114	4	170	6	N/A	N/A	N/A	N/A	4531	160	21	600	1500
	FT-32	2	44	1.75	623	6230	22	220	142	5	228	8	N/A	N/A	N/A	N/A	7080	250	12	350	1300
	FT-40	2 1/2	56	2.22	1133	11330	40	400	255	9	284	10	N/A	N/A	N/A	N/A	12744	450	6.3	180	1200
	FT-48	3	73	2.87	1841	18410	65	650	N/A	N/A	425	15	N/A	N/A	N/A	N/A	21240	750	3	75	812
	FT-64	4	98	3.87	3540	35400	125	1250	N/A	N/A	850	30	N/A	N/A	N/A	N/A	42480	1500	1	30	625
	FT-96	6	152	6.00	8496	84960	300	3000	N/A	N/A	1983	70	N/A	N/A	N/A	N/A	99120	3500	0.31	9.0	467
	FT128	8	203	8.00	15576	155760	550	5500	N/A	N/A	3399	120	N/A	N/A	N/A	N/A	169920	6000	0.14	4.0	325
	FT160	10	254	10.00	24072	240720	850	8500	N/A	N/A	5664	200	N/A	N/A	N/A	N/A	283200	10000	0.07	2.0	240
FT192	12	305	12.00	33984	339840	1200	12000	N/A	N/A	8496	300	N/A	N/A	N/A	N/A	424800	15000	0.035	1.0	167	

\*AN = 5/8"  
All Others = 3/4"

Blue = Metric (SI) Units

Black = English (US) Units

\*\*0.440 bore when used with "H" bearing code

Metric units in LPM (liquid) & ALPM (gas)

English units in GPM (liquid) & ACFM (gas)

### Abbreviations for Units of Measure:

LPM = Liters per Minute

GPM = Gallons per Minute

ALPM = Actual Liters per Minute

ACFM = Actual Cubic Feet per Minute

P/L = Pulses per Liter

P/G = Pulses per Gallon

P/Ft<sup>3</sup> = Pulses per Cubic Foot





# Model Numbering System

Please note: Highlighted areas indicate standard base price configuration.

## Pickoffs

The third digit of the calibration designator is normally not used and occupied by a dash (-).  
When required, the following codes are used:

- U — To signify required units of measure other than GPM or ACFM
- R — To signify special calibration flow range other than normal 10:1 or extended range
- B — To signify both changes in units and special flow range

The following is a listing of some of the pickoffs that are available from Flow Technology.

- 1 = Modulated Carrier, MS connector
- 2 = Magnetic, MS connector
- 3 = Magnetic, flying leads/threaded connection
- 5 = Modulated Carrier, flying leads/threaded connection
- 6 = Magnetic, MS connector, 400° C/750° F max
- 7 = Magnetic, flying leads/threaded connection 400° C/750° F max
- L = Modulated Carrier, MS connector, 400° C/750° F max
- M = Modulated Carrier, flying leads/threaded connection 400° C/750° F max
- 8 = Modulated Carrier, MS connector, 330 µH coil
- 9 = Modulated Carrier, MS connector, 5/8"-18 thread, 1mH coil
- Y = Modulated Carrier, CSA X-Proof
- Z = Magnetic, CSA X-Proof
- T1 = Modulated Carrier w/RTD, MS connector
- T2 = Magnetic w/RTD, MS connector
- T3 = Magnetic w/RTD, flying leads/threaded connection
- T5 = Modulated Carrier w/RTD, flying leads/threaded connection
- X = Modulated Carrier, I.S. approved, MS connector
- SS = Modulated Carrier, I.S. approved, flying leads/smooth body
- XX = Modulated Carrier, I.S. approved, flying leads/threaded body
- U = Magnetic, I.S. approved, MS connector
- PP = Magnetic, I.S. approved, flying leads/smooth body
- TT = Magnetic, I.S. approved, flying leads/threaded body

- Note: 1. Maximum temperature rating of pickoffs are 177° C (350° F) unless otherwise noted.  
2. See Amplifier Link literature for amplified pickoff codes.

## Materials of Construction

MATERIAL CODE	HOUSING	ROTOR	BEARING CODE
D	304 SST	17-4 PH SST	A, D, G
E	316 SST	430F SST	A, D, E, G, H
G	316 SST	316 SST	D, E, G
H	316 SST	17-4 PH SST	A, D, E, G, H
N	HAST C	HAST C	E, G
Q	PVC	PVC	E, G
R	MONEL-400	MONEL-400	D, E, G
T	CARP 20	CARP 20	E, G

<sup>1</sup> Material code "D" is for standard 6"/152 mm or larger.  
<sup>2</sup> Rotor material other than 430F SST or 17-4 PH SST will require special handling in the form of a ferrous slugged rotor or special processing electronics. Please contact the factory for any further information.

## Bearings

Bearing selection will affect Flow Range. Refer to sizing specification table for correct Flow Ranges.

- A — Ball Bearings (440 C)
- D — Carbide Journal (Carbide Shaft & Sleeve) liquid only
- E — Graphite Journal (Graphite Sleeve, 316 SST Shaft) liquid only
- G — Ceramic Journal (Ceramic Shaft & Sleeve) liquid only
- H — Ball Bearing (440 C Teflon Retainer) gas only  
(Offered on FT-64 and smaller)



# Dimensions

Series	ANSI FLANGED															
	A		B		A		B		A		B		A		B	
	150#				300#				600#				900#			
	mm	in.	mm	in.	mm	in.	mm	in.	mm	in.	mm	in.	mm	in.	mm	in.
FT-8	127	5.0	89	3.5	127	5.0	95	3.75	127	5.0	95	3.75	178	7.0	121	4.75
FT-10	140	5.5	99	3.88	140	5.5	118	4.63	140	5.5	118	4.63	140	5.5	130	5.13
FT-12	140	5.5	99	3.88	140	5.5	118	4.63	140	5.5	118	4.63	178	7.0	130	5.13
FT-16	140	5.5	108	4.25	140	5.5	124	4.88	140	5.5	124	4.88	203	8.0	149	5.88
FT-20	152	6.0	118	4.63	152	6.0	133	5.25	152	6.0	133	5.25	203	8.0	159	6.25
FT-24	152	6.0	127	5.0	152	6.0	156	6.13	152	6.0	156	6.13	229	9.0	178	7.0
FT-32	165	6.5	152	6.0	165	6.5	165	6.5	165	6.5	165	6.5	229	9.0	216	8.5
FT-40	178	7.0	178	7.0	178	7.0	191	7.5	229	9.0	191	7.5	229	9.0	241	9.5
FT-48	254	10.0	191	7.5	254	10.0	210	8.25	254	10.0	210	8.25	254	10.0	241	9.5
FT-64	305	12.0	229	9.0	305	12.0	254	10.0	305	12.0	273	10.75	305	12.0	292	11.5
FT-96	356	14.0	279	11.0	356	14.0	318	12.5	356	14.0	356	14.0	356	14.0	381	15.0
FT128	406	16.0	343	13.5	406	16.0	381	15.0	406	16.0	419	16.5	406	16.0	470	18.5
FT160	508	20.0	406	16.0	508	20.0	445	17.5	508	20.0	508	20.0	508	20.0	546	21.5
FT192	610	24.0	483	19.0	610	24.0	521	20.5	610	24.0	559	22.0	610	24.0	610	24.0

Series	WAFER				AN OR MS NPT OR BSP EXTERNAL THREADS				HOSE BARB					
	A		B		A		B		J		M		N	
	mm	in.	mm	in.	mm	in.	mm	in.	mm	in.	mm	in.	mm	in.
FT-8	48	1.88	35	1.38	62	2.45	25	1.00	62.20	2.45	12.70	0.50	14.70	0.58
FT-10	49	1.90	43	1.70	69	2.72	35	1.38	69.10	2.72	15.50	0.61	17.80	0.70
FT-12	49	1.90	43	1.70	83	3.25	35	1.38	82.60	3.25	19.10	0.75	21.10	0.83
FT-16	64	2.50	51	2.00	90	3.56	41	1.63	90.40	3.56	25.40	1.00	28.50	1.12
FT-20	64	2.50	64	2.50	103	4.06	48	1.88	103.10	4.06	31.80	1.25	34.80	1.37
FT-24	64	2.50	73	2.88	117	4.59	57	2.25	116.60	4.59	38.10	1.50	41.70	1.64
FT-32	76	3.00	92	3.62	154	6.06	70	2.75	153.90	6.06	50.80	2.00	54.90	2.16
FT-40	102	4.00	105	4.12										
FT-48	108	4.25	127	5.00										
FT-64	127	5.00	157	6.18										
FT-96	155	6.12	216	8.50										

CONSULT FACTORY

Series	DIN FLANGED													
	DN	PN 16		PN 40		PN 100		PN 160		PN 250		PN 400		
		A	B	A	B	A	B	A	B	A	B	A	B	
		mm	mm	mm	mm	mm	mm	mm	mm	mm	mm	mm	mm	
FT-8	15	127	95	127	95	178	105	178	105	178	130	178	145	
FT-10	20	140	105	140	105	140	105	140	140	140	150	140	180	
FT-12	20	140	105	140	105	140	140	178	140	178	150	178	180	
FT-16	25	140	115	140	115	140	140	203	140	203	150	203	180	
FT-20	32	152	140	152	140	152	155	203	170	203	185	203	220	
FT-24	40	152	150	152	150	152	170	229	170	229	185	229	220	
FT-32	50	165	165	165	165	165	195	229	195	229	200	229	235	
FT-40	65	178	185	178	185	178	220	254	220	254	230	254	290	
FT-48	80	254	200	254	200	254	230	254	230	254	255	254	305	
FT-64	100	305	220	305	235	305	265	305	265	305	300	311	370	
FT-96	150	356	285	356	300	356	355	356	355	356	390	356	475	
FT128	200	406	340	406	375	406	430	406	430	406	485	406	585	
FT160	250	508	405	508	450	508	515	508	515	508	585	-	-	
FT192	300	610	460	610	515	610	585	610	585	610	690	-	-	

Blue = Metric (SI) Units      Black = English (US) Units  
mm = millimeters                  in. = inches

- Note: 1) Consult factory for Grayloc end fitting dimensions.  
2) All ANSI flanged meters will have a 1" NPT spud around pickoff.  
3) NPT meters 2 1/2" and larger will have a 1" NPT spud around pickoff.  
4) Wafer meters 1" and larger will have a 1" NPT spud around pickoff.

Specifications and dimensions are for reference only and are subject to change without notice.

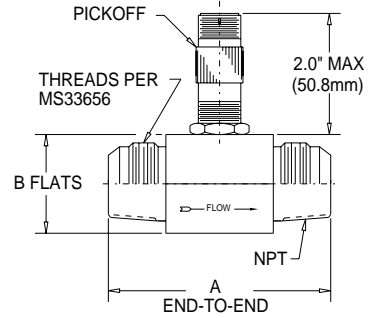

Composite drawing showing MS end connections on the upper portion of the flowmeter and NPT/BSP threads on the lower portion. Pickoff is a 2-pin MS connector.

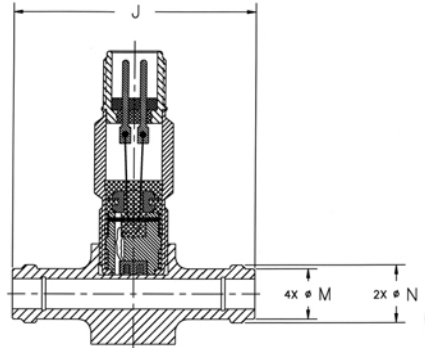

Hose Barb flowmeter with 2-pin MS connector pickoff.

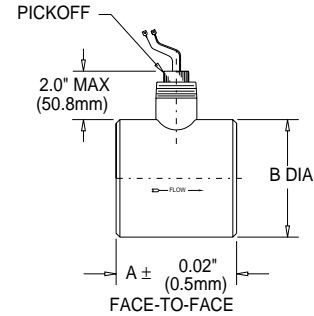

FT Series flowmeter with wafer end connections. Pickoff with flying leads and a 1" NPT enclosure connection on FT-16 and larger.

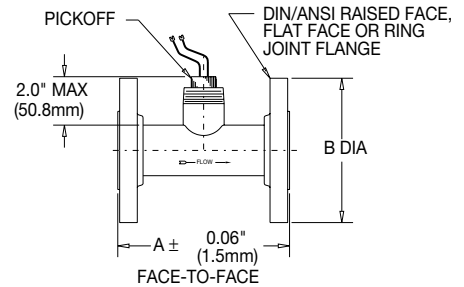

FT Series flowmeter with flanged end connections. Pickoff with flying leads and a 1" NPT enclosure connection.

## Local Representative:



4250 E. Broadway Road, Phoenix, Arizona 85040 USA  
Tel: (602) 437-1315 • Fax: (602) 437-4459 • Toll Free: 1-800-528-4225  
E-mail: ftimarket@ftimeters.com • Web: www.ftimeters.com  
DB 62042 Rev E © 2000 FTI Flow Technology, Inc. Printed in USA